



Spare Parts Catalogue

GX12-29

Handling systems | **Deichselstapler**





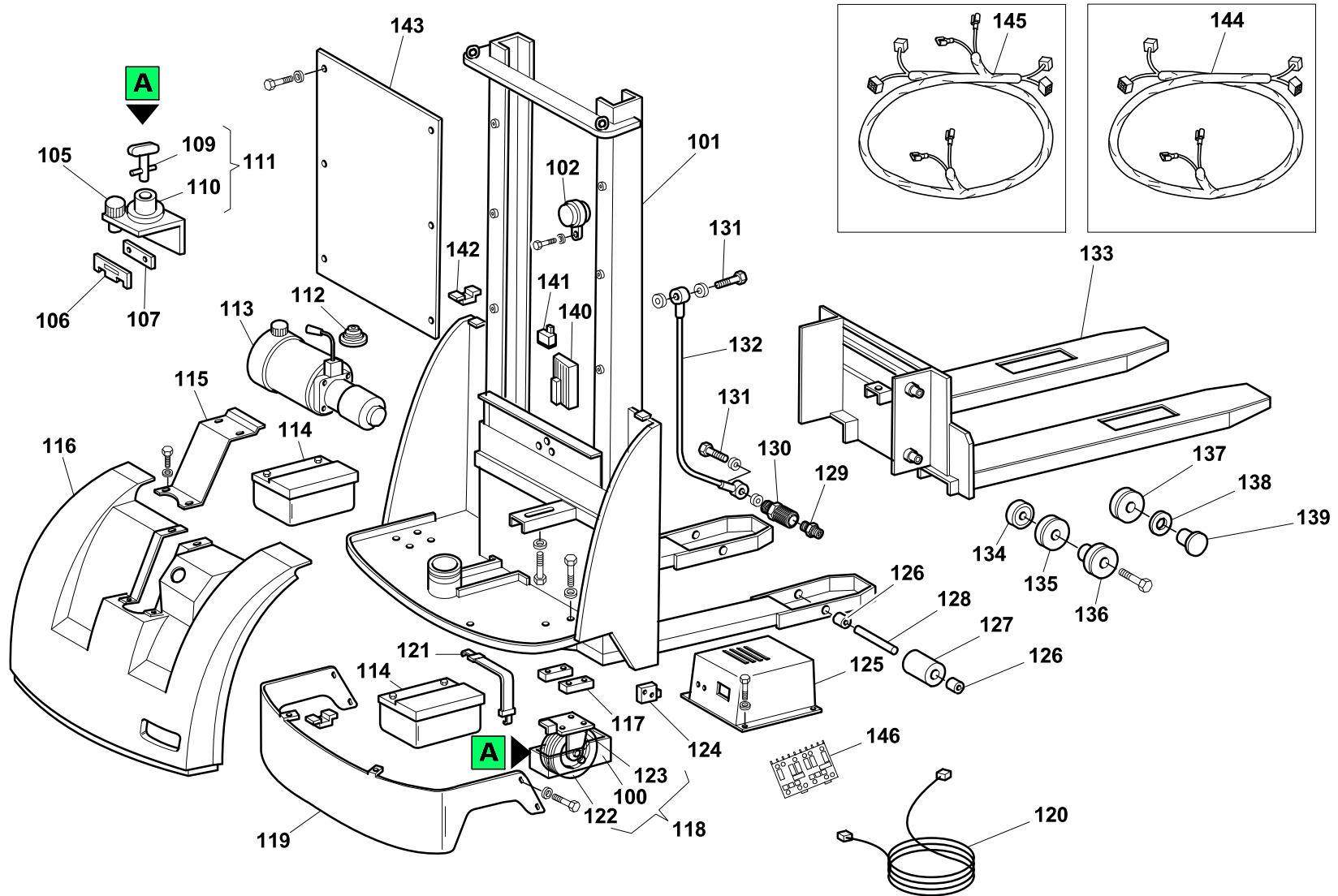

Valid for machine code: **HC612000000**

Revision: **0 (11/2006)**



Copyright 2010 Pramac Group, All Rights Reserved.



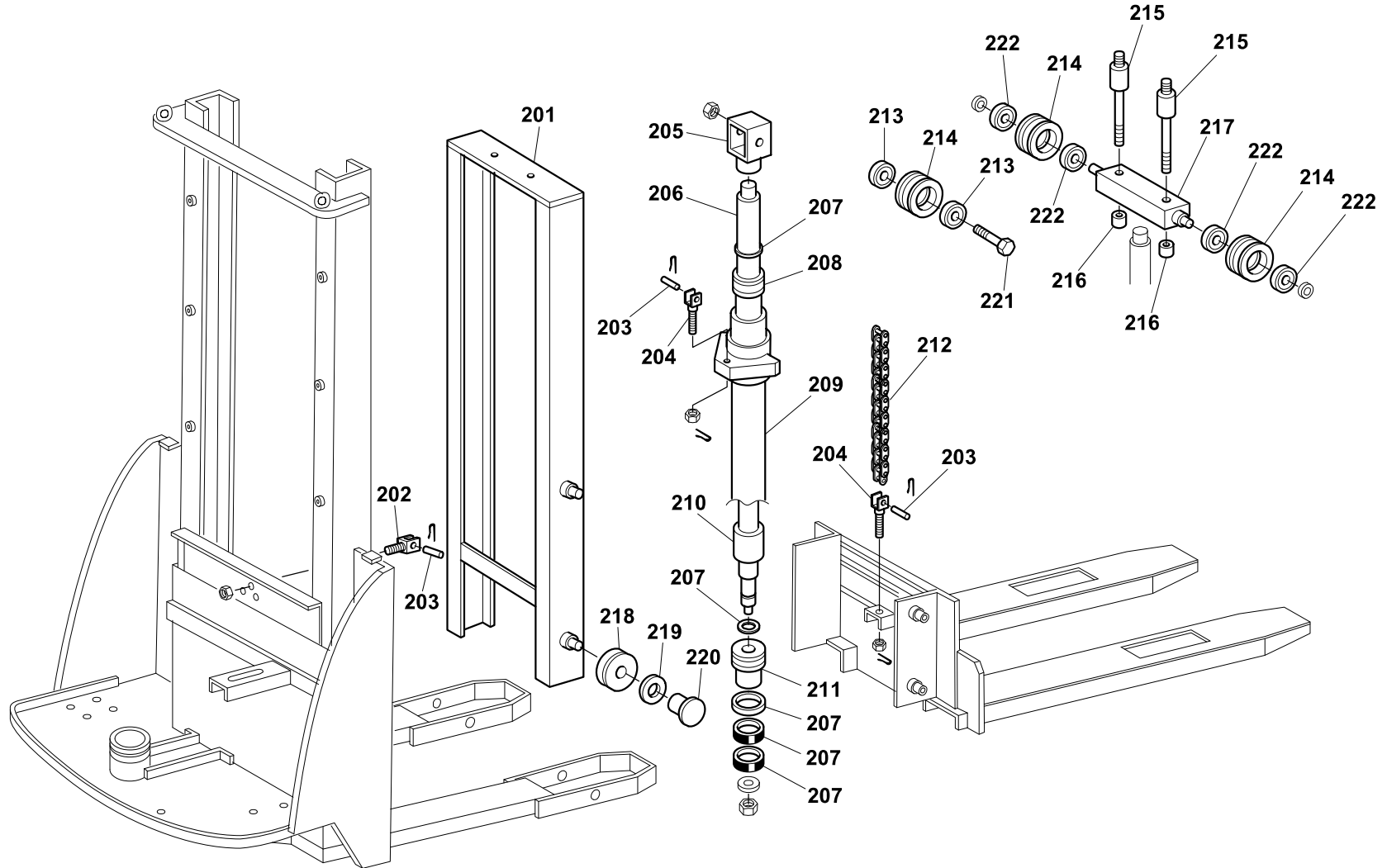

Position	Part Number	Description	Notes
101	V0311060034-PRAMAC	Telaio Gx 12/29 Vern.verde Pramac	-
102	G075110	Horn 24v Dc	-
105	G070625	Fuse Holder Screw Cap + Fuse 6.3a	-
106	G077540	Fuse 160a (rfm Reghel)	-
107	G070603	Fuse Holder X Fuse 160amp	-
109	G075220	Key X Battery Disconnecting Switch	-
110	G075221	Battery Disconnecting Switch Block	-
111	G075102	Battery Disconnecting Switch 1 Pole	-
112	G052002	Rubber Bellows (for Stackers)(0-rab/010)	-
113	 G081021	Hydraulic Unit 222353003 Up100 (tx12- Gx10-12)	Gültig für Produkte mit der Seriennummer bis 2003HG001641
	 G081035	Hydraulic Power Pack '06 Tx12-gx10/12	
	 G081029	Central S3010001.000 X Tx12 - Gx10/12	Gültig für Produkte mit der Seriennummer ab 2003HG001642
114	G089702	Battery "exide Gel" 100ah-12v	-
	G099300006	Battery 92ah-12v	-
	G099300062	Battery 132ah-12v Trazione	-
115	V0310018015-PRAMAC	Hood Guard Lock Gx10-12 Green Pram.	-
116	S0310018010	Hood Guard Gx 10-12	-
117	V01941-9005	Painted Wheel Spacer '06 Gx	-
118	G053328	Polyurethane Wheel T150x40/49 Cc Spgp60 +par.	-
119	S0313010039	Motor Wheel Protection Gx10 Painted	-
120	G079311	Battery Charger Cable L1500mm Schuko Socket	-
121	G000112	Battery Elastic Webbing Gx10/12	-
	G000113	Battery Elastic Webbing Gx12 Plus	-
122	G053334	Polyurethane/aluminium Wheel T8017cc New X G10-te	-
123	G053412	Supporto Ruota 150-160/50 H.m.120 Mm.40	-
124	G075006	Microswitch Rolle	-
125	G008007	Open Frame Battery Charger 14a-24v X Gx10-12 Gel	-
	G099300027	Open Frame Battery Charger 20a-24v (gx 12) 240v	-
	G099300059	Open Frame Battery Charger 20a-24v X Gx 12	-
	G099300066	Open Frame Battery Charger 20a-24v(straddle)120v	-
126	S0302016026	Roller Spacer Sing.tx-gx (l.15) Zinc	-
127	S0302020117	Polyurethane Roller D82x70 + Bearing	-
128	S0302015025	Clevis Pin Tx/gx/lx "burnished"	-
129	G084103	Male/male Adaptors 3/8"	-
130	G085003	Flow Control Valve 3/8"	-
131	G084001	Screw Perforate (4 Holes) 3/8" L 29 -0,5/0 Ch22	-
132	G083012	Tube R1at 3/8"	-

Position	Part Number	Description	Notes
133	S0307050082	Complete Fork Painted Tx/gx 12/29	-
134	G010151	Bearing 6305 (25-62-17)	-
135	S0207016006	Sliding Roll Fork Tmc 10/16	-
136	S0207018001	Fork Roller Guide Gx/tx	-
137	G019306	Bearing D70 (csf.002)	-
138	G019310	Pushing Disc (10004.102)	-
139	G019309	Side Sliding Block (10002.102)	-
140	 G076024	Electronic Board Curtis 1228-110a 24vngx12 (calibrated)	Gültig für Produkte mit der Seriennummer ab 1999HG000001 zu 2000HG014135
	 G075050	Pramac Controller Rf050h70-120a X Gx 10	Gültig für Produkte mit der Seriennummer ab 2000HG001436 zu 2004HG000739
	 G076024	Electronic Board Curtis 1228-110a 24vngx12 (calibrated)	Gültig für Produkte mit der Seriennummer ab 2004HG000740
141	G077201	Relay 30a 24v Contatto A Scambio	-
142	G034903	Cage Nut M8 Zn	-
143	S0310018006	Plexiglass Guard Tx10/20-16 Tx12/29-35 Gx12/29-35-38 Gx10/16 Fx12/29-35-38 G10 Vers.2	-
144	 S0318028018	Electric Wiring Cables Gx 12 (curtis)	Gültig für Produkte mit der Seriennummer ab 1999HG000001 zu 2000HG001435
	 S0318028013	Electric Wiring Cables Gx 10-12 (pramac)	Gültig für Produkte mit der Seriennummer ab 2000HG001436 zu 2003HG001641
	 S000045001	Cablaggio Elettrico Gx 10-12 (pramac)	Gültig für Produkte mit der Seriennummer ab 2003HG001642 zu 2004HG000739
	 P0CD00009	Complete Harness Kit Gx12 '03	Gültig für Produkte mit der Seriennummer ab 2004HG000740
145	S0319060047	Second Speed Wiring Gx12	-
146	PTB00001	Electronic Board For Open Battery Charger Cx Plus/cx/gx10/tx12/gx12	-
	PTB00005	Scheda Elettronica Per Raddriz.	-

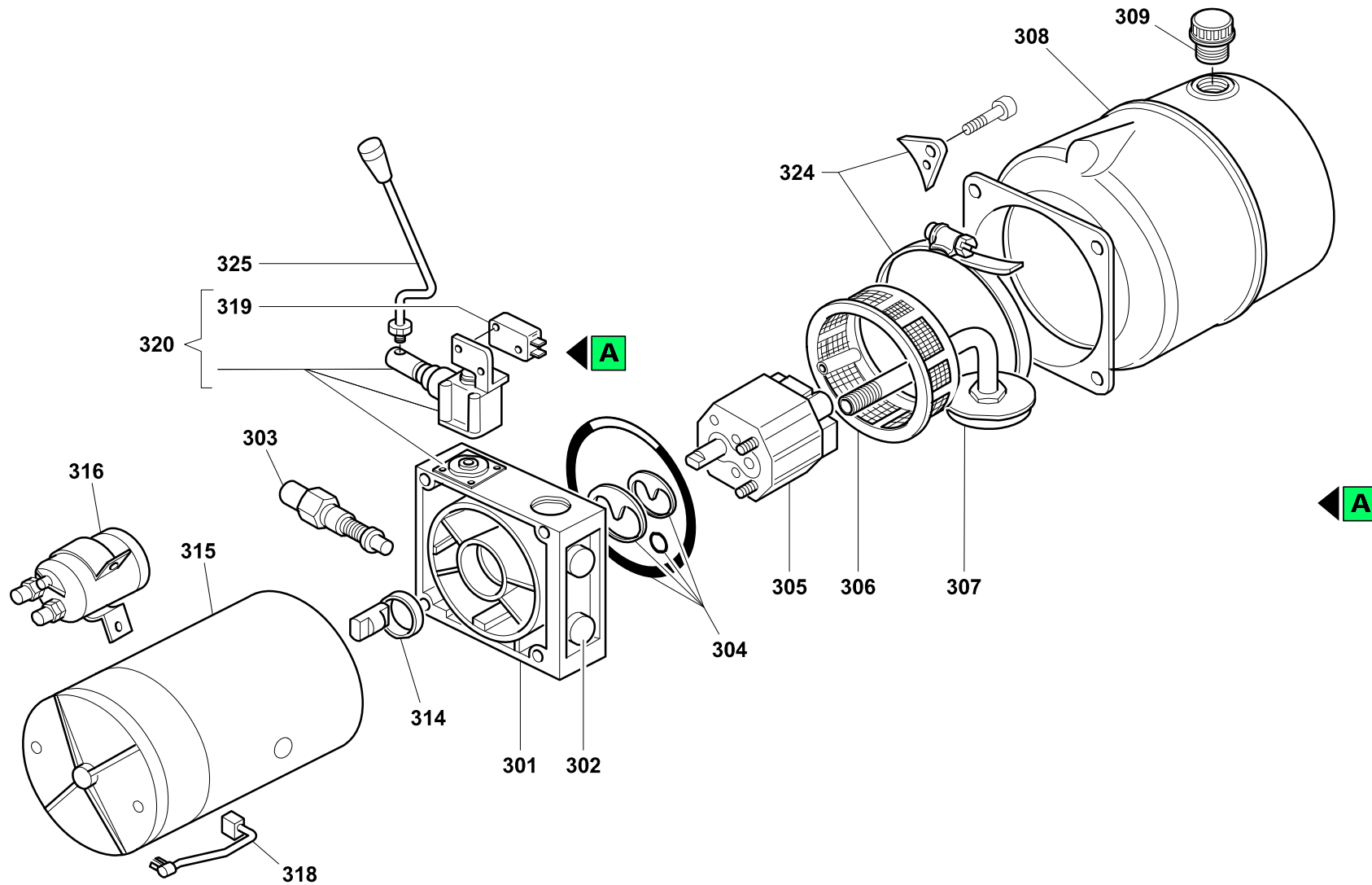

Position	Part Number	Description	Notes
201	S0305010170	Welded Second Stage Tx-gx 12/29	-
202	S000045502	Pettine Corto X Carr. 12q.li Catena Singola	-
	S0307015015	Short Chain Holder Te-tm-l/vt Zinc Plated	-
203	G062102	Flayer Chain Pin B1546 D6x33	-
204	S0300155003	Chain Holder Stacker 12q Single Chain	-
205	S0306051022	Cast Iron Pulley Holder Te-tm-l Painted	-
206	S0306053018	Piston Rod H2900	-
207	G090005	Gasket Set Fx12/g10/gx12//lr/te/tmc/tx12 Old	-
208	S0306041004	Cylinder Nut Ring Te/tm 10-12/29-36	-
209	 S000045034	Complete Cylinder '06 Fx-gx-tx12/29	-
	 S0306010159	Complete Cylinder Tx-gx 12/29 Painted	-
210	S000045602	-	-
	S0306056017	Cylinder Support L.105 Te-tm	-
211	S0306041008	Piston Te/tm 10-12/29-36	-
212	G062022	Flayer Chain Stub B1544-117p	-
213	PMT240703	Sost. Con G010401	-
214	S0300201034	Chain Pulley Sing. X12q Burnished	-
215	S0306015052	Free Lift Pin L10-I16	-
216	S0306015036	Free Lift Pin Spacer Te-tm	-
217	S0306012072	Double Pulley Holder L16 Painted "1998"	-
218	G019306	Bearing D70 (csf.002)	-
219	G019310	Pushing Disc (10004.102)	-
220	G019309	Side Sliding Block (10002.102)	-
221	S0306055043	Cast Iron Pulley Pin Holder Burnished	-
222	G010403	Bearing 6005 2rs (25-47-12)	-



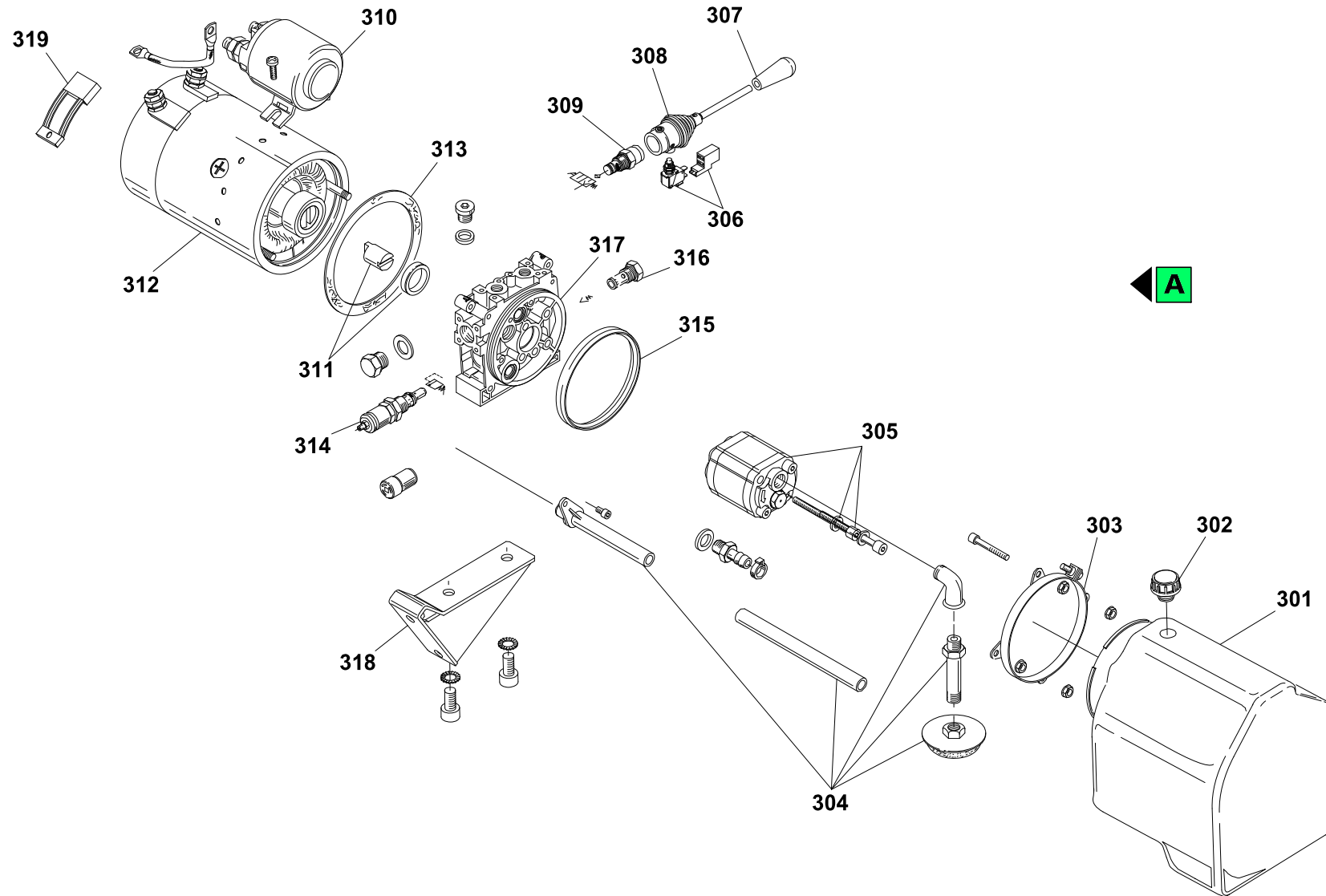

Position	Part Number	Description	Notes
301	G082195	Body Up100 K1g3-06+oil Seal	-
302	G082171	Non Return Valve Rs3/817-03	-
303	G082107	Relief Valve Vm01 Hdm10 T.95-210	-
304	G082165	Body Gasket Set Up100	-
305	G082100	Pump Ap100/1.7 S.409+cop.748220020	-
306	G082090	Filter Conv.150 Micron (757500070)	-
307	G082196	Gruppo A.h105178-900 250m	-
308	G082228	Tank Up100 P08,or-bbt (673450200)	-
309	G082099	Loading Cap Sf1/2g(hidr.678000310)	-
314	G082158	Joint E145 M.c.c T.e	-
315	G082230	Engine C240ak/y0/d02p 024v 2.2	-
316	G082127	Complete Relay 24v C.c. P.c-e-f-g (ef.)	-
318	G082233	Cable + Brushes 24v	-
319	G082223	Microswitch For Manual Command Up50-up100	-
320	G082224	Valve Zr817/22-tvml + Cap	-
324	G082227	Tank Clamping Set Pl. Up100 6-14l.	-
325	G082232	Lever Stick Al029 Up100	-
999	 G081021	Hydraulic Unit 222353003 Up100 (tx12- Gx10-12)	Gültig für Produkte mit der Seriennummer bis 2003HG001641

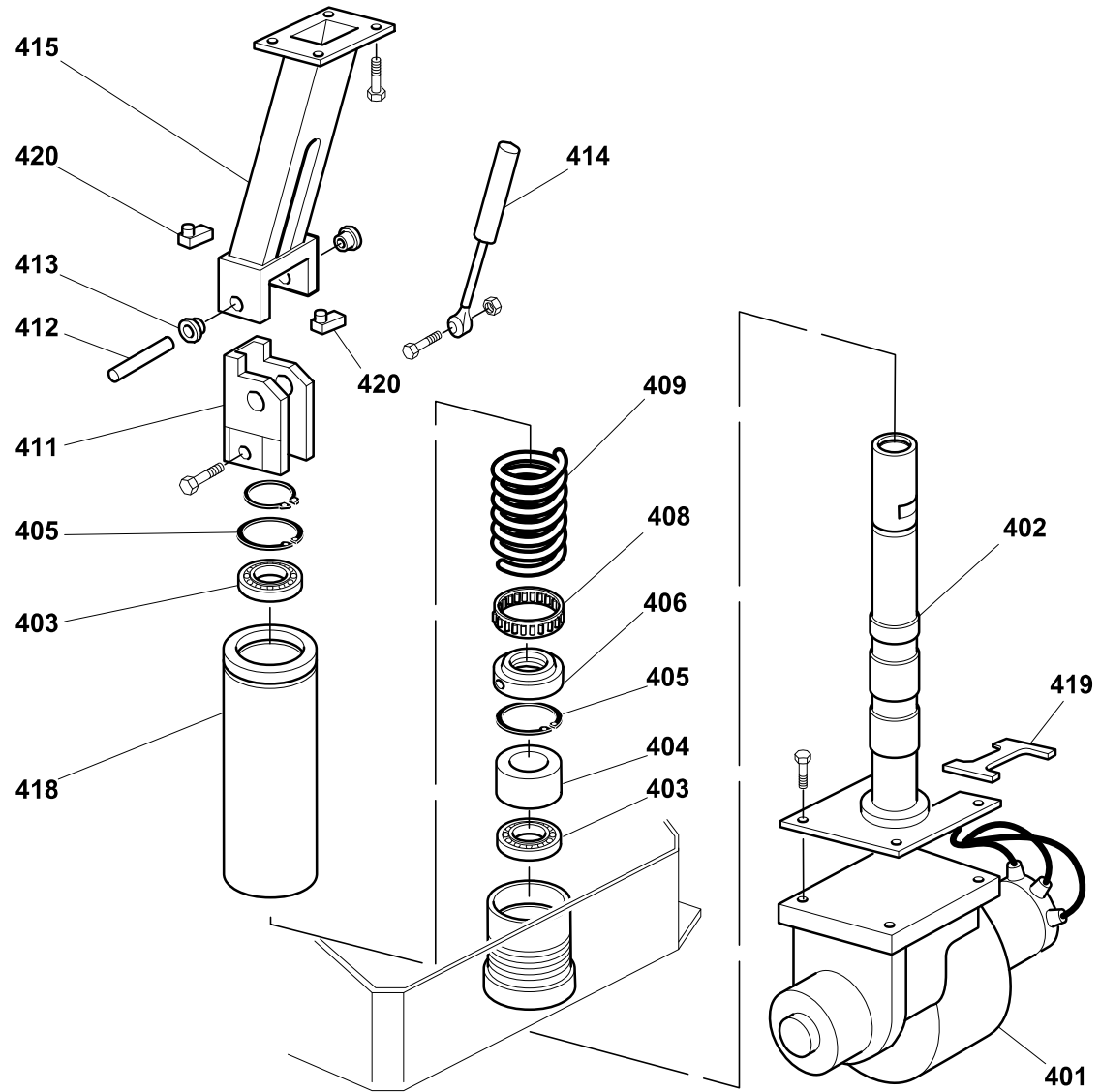

Position	Part Number	Description	Notes
301	PCY61214500	Reservoir Bottle	-
302	PCY49154500	Tappo Serbatoio Olio Tx Hydr-app	-
303	PCY25004800	Band For Hydraulic Unit H	-
304	PCY12002	Kit Tubi Tx Hydr-app	-
305	PCY17050006	Hydraulic Unit Pump Hx	-
306	PCY46109900	Microswitch	-
307	PCY49104600	Pomello Centralina Hydr-app	-
308	PCY25005800	Hydraulic Power Pack Complete Lever	-
309	PCY20023000	Valvola Tx10/12	-
310	PCY46113300	Relais 24v 80a Iskra (11250143)	-
311	PCY60410600	Giunto A Penna Per "mc" Con Motore Elettrico 2.05-2.2kw E Pompe Gr.1	-
312	PCY24011600	Control Box Motor	-
313	PCY61200100	Gasket For Hydraulic Unit H	-
314	PCY21000001	Valvola Max 50-210 Bar	-
315	PCY61212400	Hydraulic Unit O-ring Hx	-
316	PCY20020400	Hydraulic Unit Retention Valve Hx	-
317	PCY71013005	Central Flange	-
318	PCY17010067	Piedino Ancoraggio Tx Hydr-app	-
319	PCY00004056	Brush Kit Gx/10/12 Tx12	-
999	 G081029	Central S3010001.000 X Tx12 - Gx10/12	Gültig für Produkte mit der Seriennummer ab 2003HG001552



Position	Part Number	Description	Notes
401	 G074426	Motor Wheel 700w 24v Magn.perm.x Gx12	Gültig für Produkte mit der Seriennummer bis 2002HG001773
	 G074431	Motor Wheel 700w 24v Permanent Magnet X Cx14	Gültig für Produkte mit der Seriennummer ab 2002HG001774
402	S0313060047	Motor Wheel Support Gx 12 Painted	-
403	G010214	Bearing 6010 2rs(50-80-16)	-
404	S0303018002	Motor Wheel Sliding Bushing L10	-
405	G090021	Stackers Motor Wheel Seeger Kit	-
406	S0303016030	Motor Wheel Shaft Washer L10	-
408	S0313080057	Complete Motor Bearing Stacker	-
409	G001108	Spring De78 F.11x162 P.22 Xg10	-
411	P0KI00006	Tiller Kit L/k20	-
412	S0304013027	Handle Pin Gx-lx-k20 "burnished"	-
413	G016353	Self-lubricating Bushing 20x28x35 L=20	-
414	G001703	Gas Spring 198.236.17-gf2	-
415	S0304010142	Handle Support Painted "l"-k20"	-
418	S0303010139	Spring Loader Lx-gx Zinc Plated	-
419	S0303010153	Motor Wheel Wiring Bracket L10-I16	-
420	G075004	Microswitch For Tow Bar L10	-

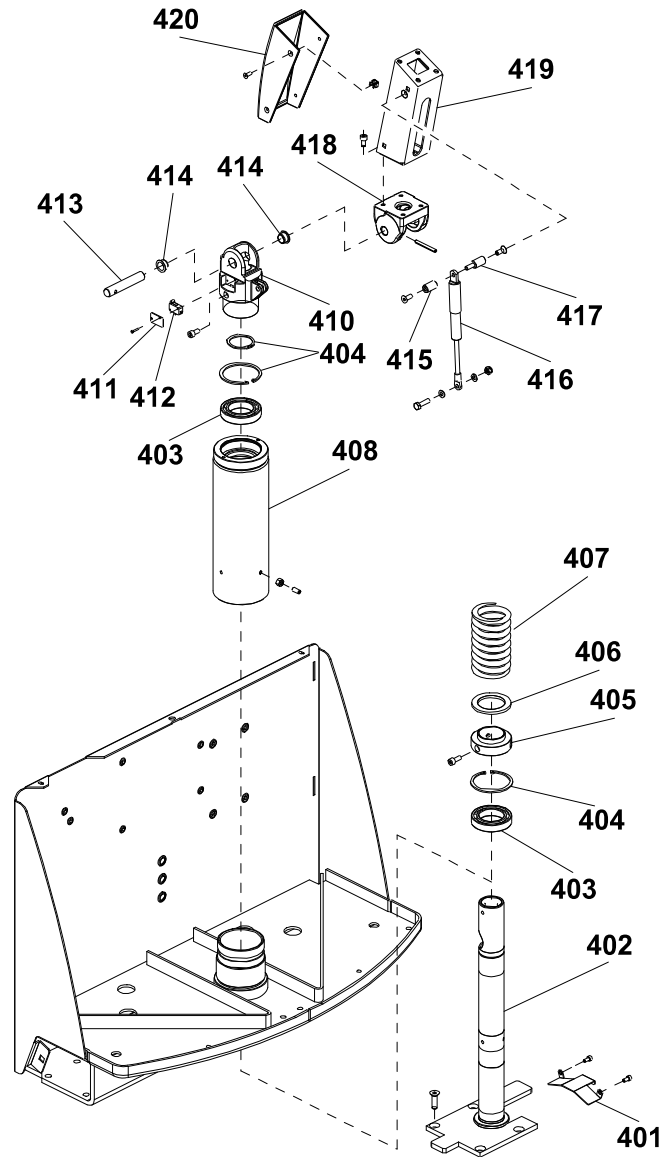

Position	Part Number	Description	Notes
401	S0303010153	Motor Wheel Wiring Bracket L10-I16	-
402	S0313060047	Motor Wheel Support Gx 12 Painted	-
403	G010214	Bearing 6010 2rs(50-80-16)	-
404	G090021	Stackers Motor Wheel Seeger Kit	-
405	S0303016030	Motor Wheel Shaft Washer L10	-
406	S0313080057	Complete Motor Bearing Stacker	-
407	G001108	Spring De78 F.11x162 P.22 Xg10	-
408	S0303010139	Spring Loader Lx-gx Zinc Plated	-
410	V000044101-90050	Supporto Timone Gx-lx '03 Vern	-
411	S000044034	Protection Plate Tiller Microswitch Gx-lx Dark Zinc Coated	-
412	G075004	Microswitch For Tow Bar L10	-
413	S000025501	Tiller Pin Gx-lx '03 Burnished	-
414	G016307	Boccola Flangiata Du 18-20	-
415	S000025503	Distanziale Madre vite Timone Gx-lx '03 Brunito	-
416	G001703	Gas Spring 198.236.17-gf2	-
417	S000025502	Distanziale Vite-madre vite Timone Gx-lx '03 Brunito	-
418	S000045104	Tiller Bracket '03 Fx-gx-lx Galvanized	-
419	V09415-9005	Tiller Box Gx-lx '03 Painted	-
420	S000025901	Coperchio Timone Gx-lx '03	-

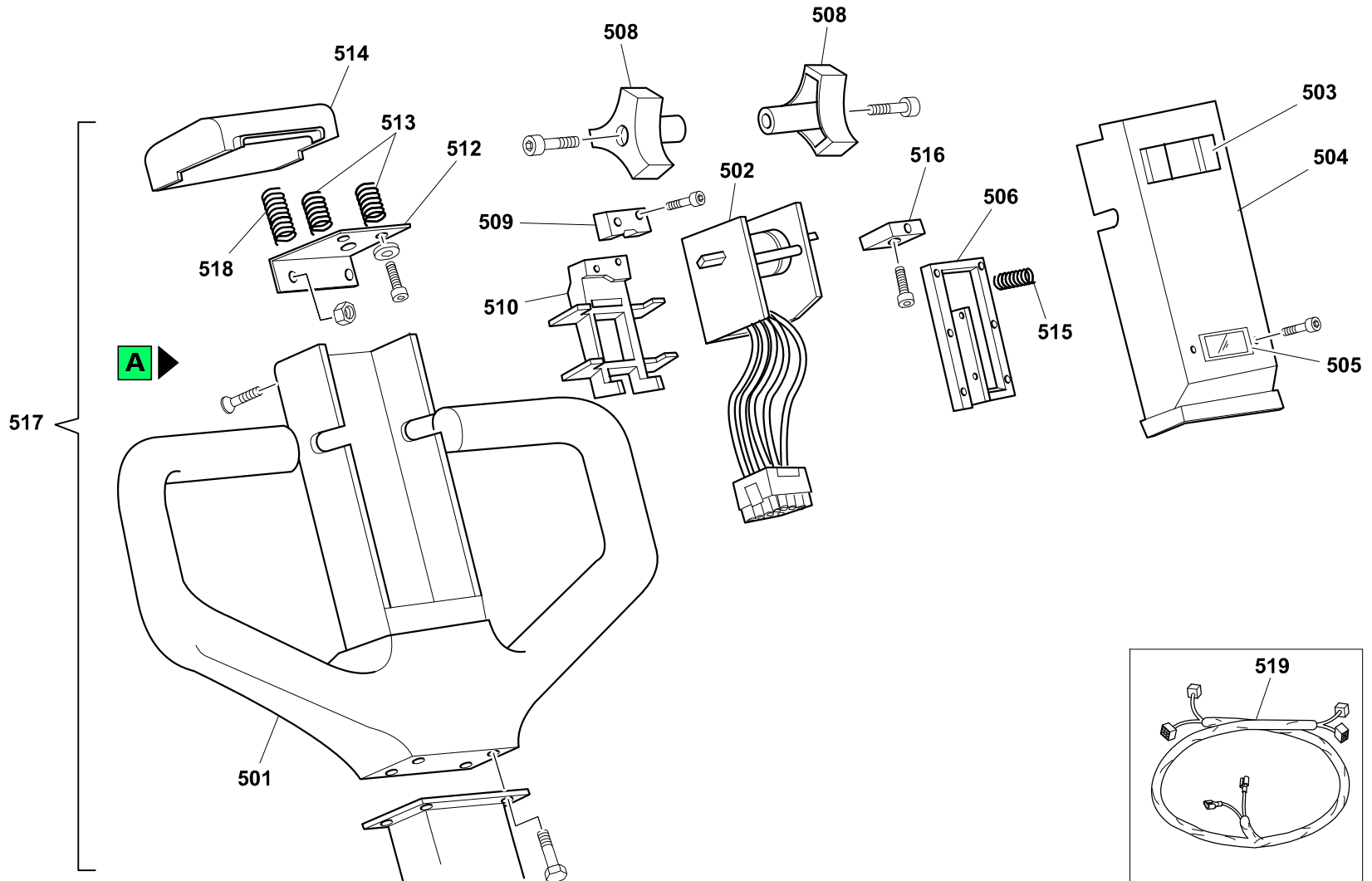

Position	Part Number	Description	Notes
501	S0304010208	Coated Handle (poly) Lk	-
502	G077002	Electronic Throttle Et160	-
503	S0304018020	Handle Pushbutton Switch Lk	-
504	S0304018019	Cover Lk X Stackers	-
505	G079005	Battery Level Gauge Curtis	-
506	S0304018022	Handle Microswitch Support Lk	-
508	S0304018018	Handle Butterfly Lk	-
509	G075016	Microswitch 5a 250v	-
510	S0304018021	Handle Support Potentiometer Lk	-
512	S0304017011	Handle Emergency Support Plate Lk	-
513	G001132	Spring De11 Wire 1 - 4 Turns L10 Mol/zn	-
514	S0304018017	Handle Emergency Lk	-
515	G001131	Spring De5,6 F0,5 - 10 Turns L20 Zinc Plated	-
516	G075017	Microswitch Xg52-j21	-
517	S0304150299	Complete Handle Lk Gx12	-
518	G001134	Spring De12,3 F1 - 9 Turns - L=24 Zinc Plated	-
519	S0319012001	Cable Tiller L/g (curtis)	-

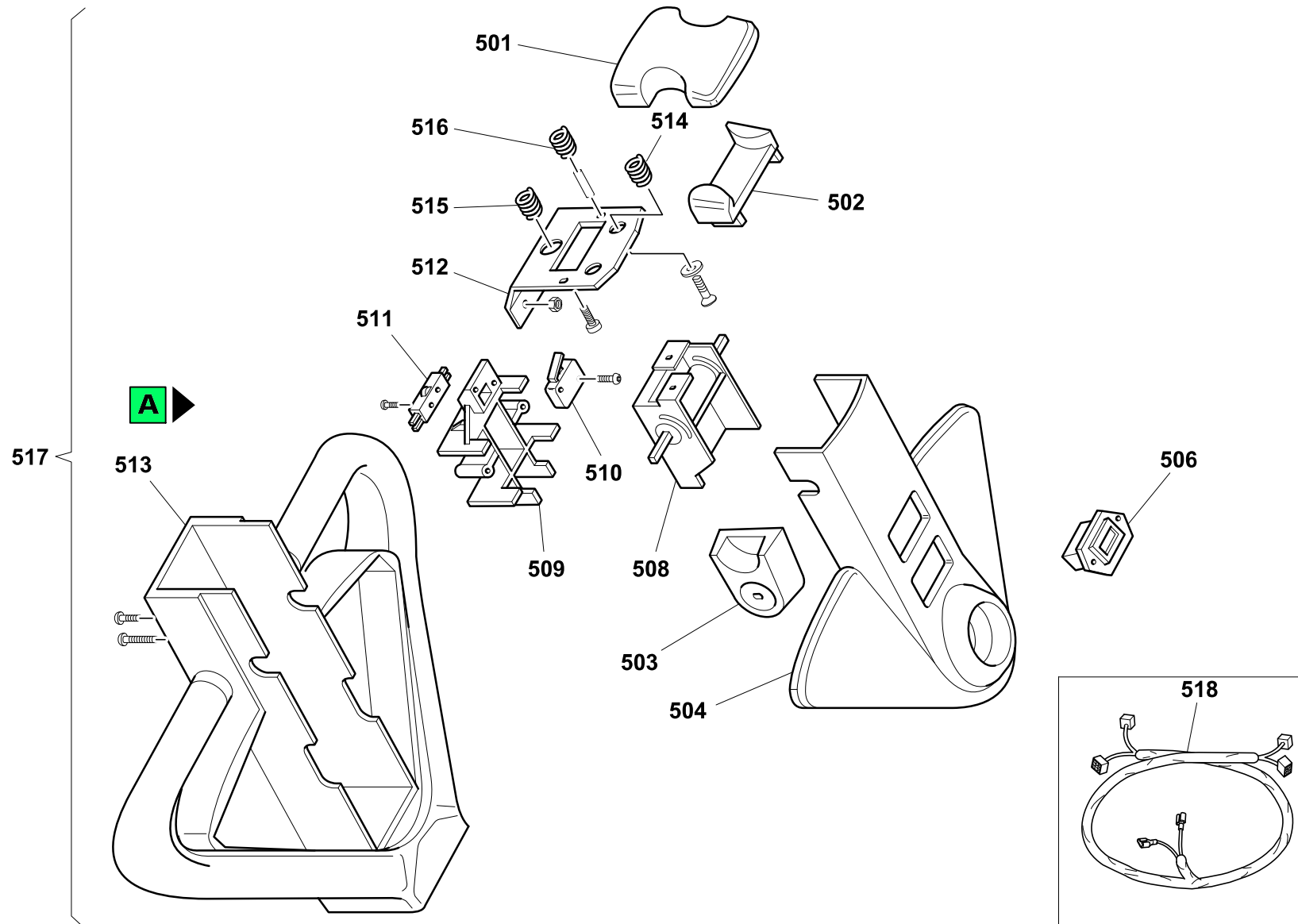

Position	Part Number	Description	Notes
501	S0304178033	Handle Emergency '00	-
502	S0304178032	Handle Horn Rocker Switch '00	-
503	S0304178031	Handle Butterfly '00	-
504	S0314108031	Handle Cover '00 Gx Stackers Series	-
506	G079005	Battery Level Gauge Curtis	-
508	⚠ G077007	Electronic Throttle Gph/ht3 X Gx10 Wired	Gültig für Produkte mit der Seriennummer bis 2004HG000739
	⚠ G077002	Electronic Throttle Et160	Gültig für Produkte mit der Seriennummer ab 2004HG000740
509	S0304178034	Handle Potentiometer Support '00	-
510	G075017	Microswitch Xg52-j21	-
511	G075016	Microswitch 5a 250v	-
512	G07330	Handle Emergency Support Plate '00	-
513	S0304178044	Coated Handle '00 (poly)	-
514	G001132	Spring De11 Wire 1 - 4 Turns L10 Mol/zn	-
515	G001134	Spring De12,3 F1 - 9 Turns - L=24 Zinc Plated	-
516	G001131	Spring De5,6 F0,5 - 10 Turns L20 Zinc Plated	-
517	⚠ S0314110065	Handle '00 Complete Stacker Gx	Gültig für Produkte mit der Seriennummer bis 2004HG000739
	⚠ S000045005	Complete Tiller '00 Gx12	Gültig für Produkte mit der Seriennummer ab 2004HG000740
518	⚠ S0319012001	Cable Tiller L/g (curtis)	
	⚠ P0CD00015	Electric Wiring Gx10/12 Edition li	

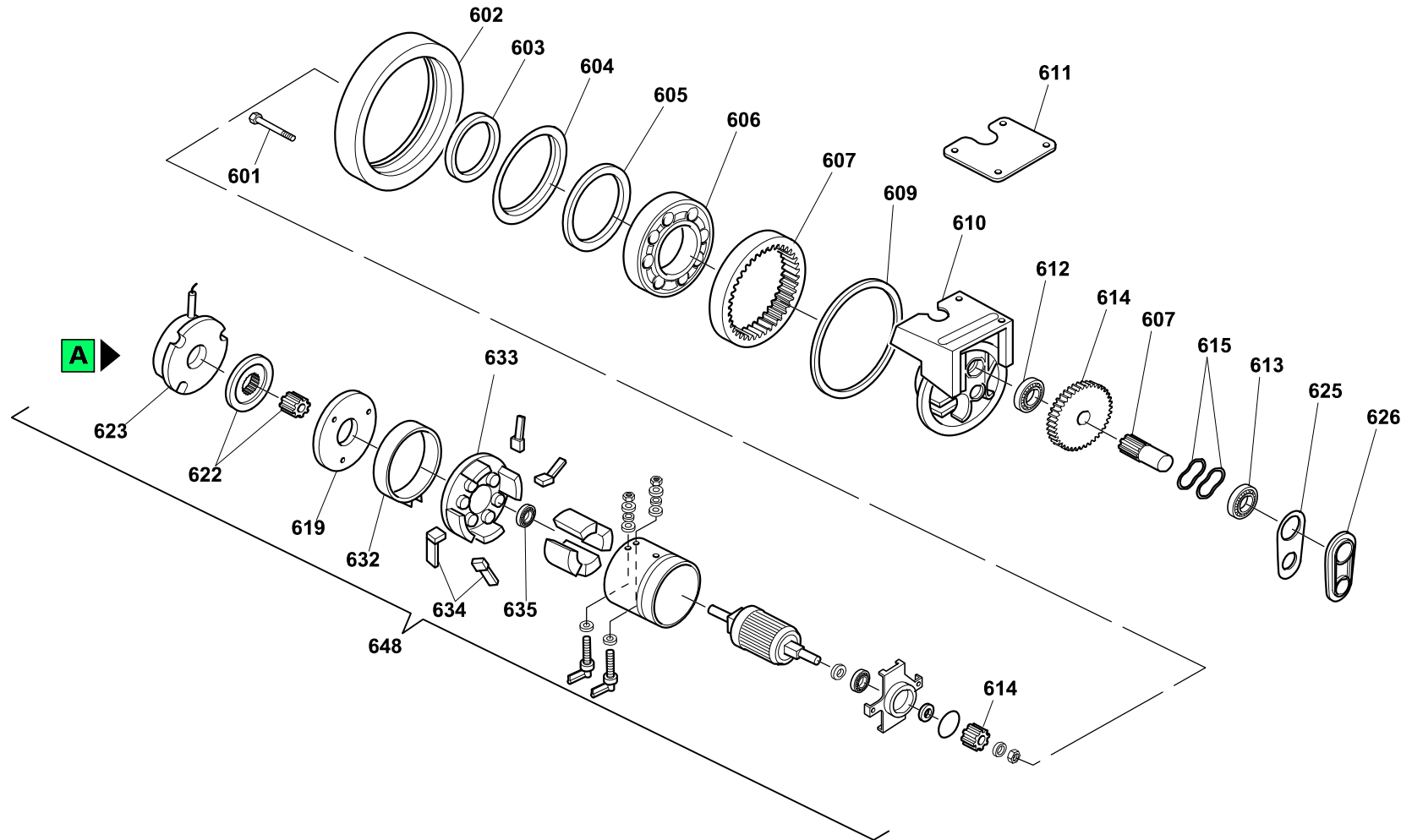

Position	Part Number	Description	Notes
601	G073242	Screw Wheel	-
602	G073243	Motor Wheel Rubber Ring Te96/cx14/gx12	-
	G073330	Motorwheel Rubber Ring Eco. 250x76 13270	-
	G073331	Motor Wheel Adiprene Ring Te96/cx14/gx12	-
	PLC13265S	Rubber Ring Gx12-cx14-te	-
	PLC13268S	Anello Motoruota Vulk. Scolpito Te/gx12/cx14	-
603	G073006	Motor Wheel Ring	-
604	G073008	Protection Ring	-
605	G073007	Motor Wheel Gasket	-
606	G073009	Bearing	-
607	G073260	Pinion +crown Wheel	-
609	G073245	Motor Wheel Gasket	-
610	G073246	Motor Wheel Casting	-
611	G073011	Motor Wheel Gasket	-
612	G073247	Bearing	-
613	G073026	Bearing 16006	-
614	G073029	Pinion + Driver Wheel	-
615	G073030	Compensation Ring	-
619	G073016	Brake Holder Plate	-
622	G073066	Brake Lining +hub	-
623	G073036	Electric Brake K1 Hole Cima 24v	-
625	G073013	Gasket	-
626	G073014	Cover	-
632	G073032	Paddled Clamp	-
633	G073019	Slip Support	-
634	G073068	Brushes Kit Motor 24v	-
635	G073249	Slip Bearing 6201 2rsrc3	-
648	G073209	Permanent Magnet Motor.	-
999	 G074426	Motor Wheel 700w 24v Magn.perm.x Gx12	Gültig für Produkte mit der Seriennummer bis 2002HG001773

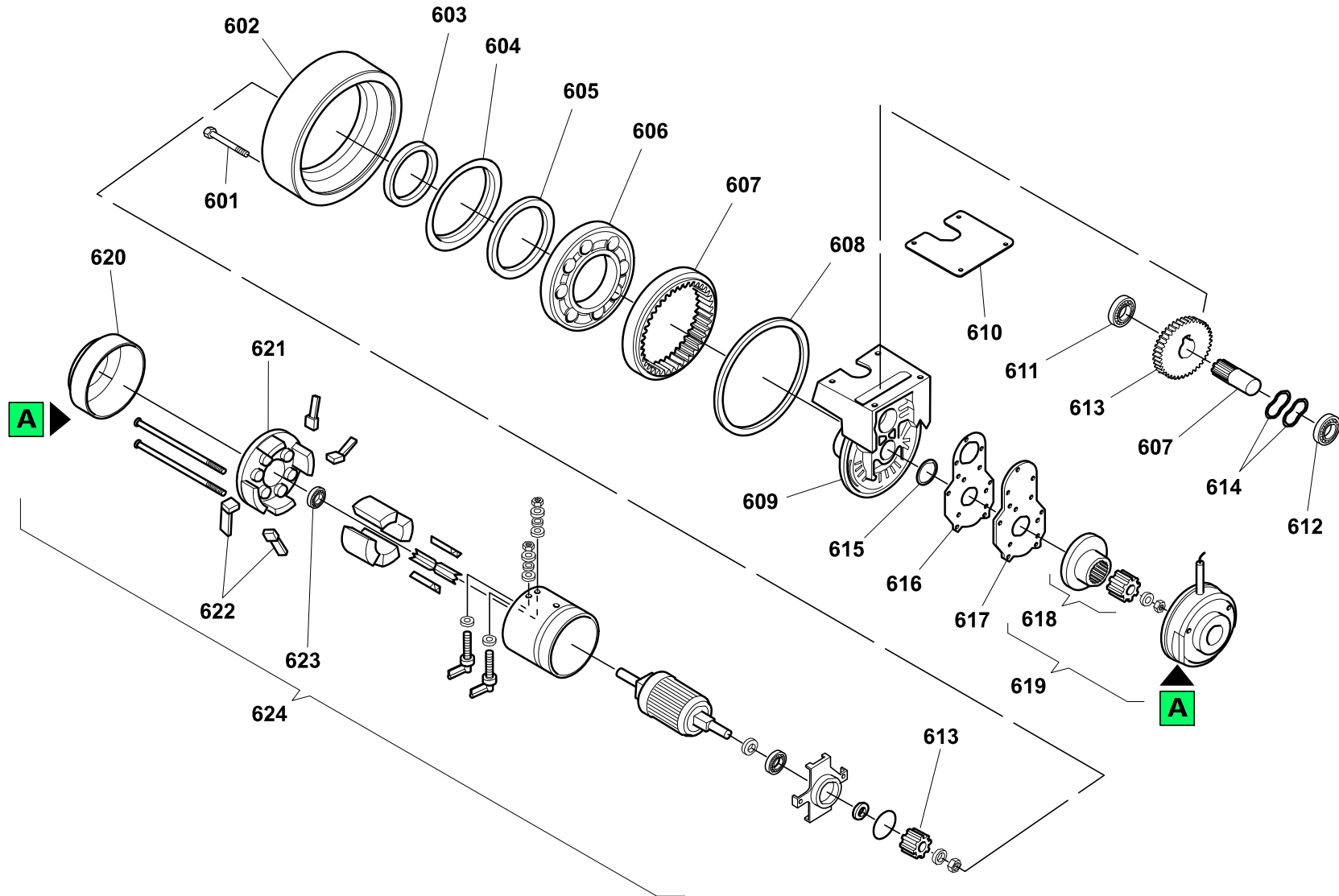

Position	Part Number	Description	Notes
601	G073242	Screw Wheel	-
602	G073243	Motor Wheel Rubber Ring Te96/cx14/gx12	-
	G073330	Motorwheel Rubber Ring Eco. 250x76 13270	-
	G073331	Motor Wheel Adiprene Ring Te96/cx14/gx12	-
	PLC13265S	Rubber Ring Gx12-cx14-te	-
	PLC13268S	Anello Motoruota Vulk. Scolpito Te/gx12/cx14	-
603	G073006	Motor Wheel Ring	-
604	G073008	Protection Ring	-
605	G073007	Motor Wheel Gasket	-
606	G073009	Bearing	-
607	G073260	Pinion +crown Wheel	-
608	G073245	Motor Wheel Gasket	-
609	G073246	Motor Wheel Casting	-
610	G073011	Motor Wheel Gasket	-
611	G073247	Bearing	-
612	G073026	Bearing 16006	-
613	G073029	Pinion + Driver Wheel	-
614	G073030	Compensation Ring	-
615	PLC90117	Protection Ring	-
616	PLC13912	Motor Wheel Gasket Cx14	-
617	PLC13716	Brake Holder Plate Cx14	-
618	G073066	Brake Lining +hub	-
619	G073036	Electric Brake K1 Hole Cima 24v	-
620	PLC35105	Motor Fan Protection Cx14	-
621	PLC31885	Manifold Support Cx14	-
622	G073068	Brushes Kit Motor 24v	-
623	G073249	Slip Bearing 6201 2rsr3	-
624	PLC30294	Cx 14 Drive Motor	-
888	 G074431	Motor Wheel 700w 24v Permanent Magnet X Cx14	Gültig für Produkte mit der Seriennummer ab 2002HG001774